



# Veolia Water

Interactive Exhibit >> Saudi Water & Power Forum (SWPF) >> Client Approved 2008

Our task was to create a Trade Forum stall for a specific Brand, Veolia Water Solutions and Technologies.

With its principle manufacturing being water filters, the concept design for this interactive module was simply to fill a clear tank - with the attractive qualities of a lolly jar - full of logo branded foam balls in red and white (Veolia brand colours) representing the notion of filtering balls in water.

The visitor is able to blast the balls with air, by turning a large wheel. The balls would scatter and settle, similar to filtering granules in water.

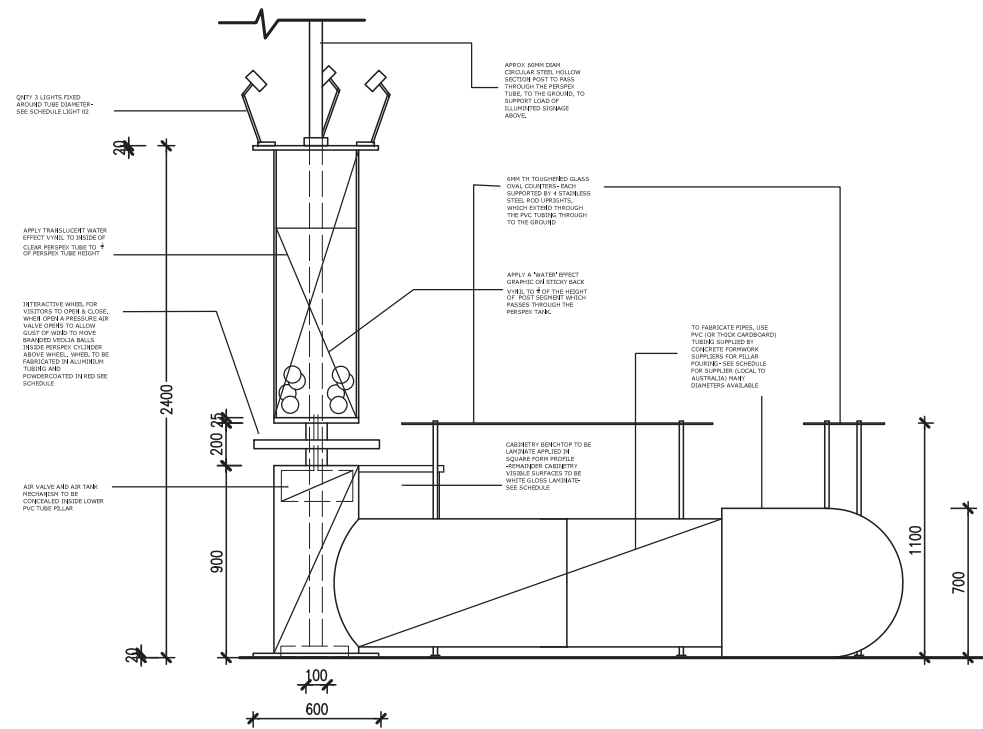

INTERACTIVE MODULE 03 ELV1  
1:20

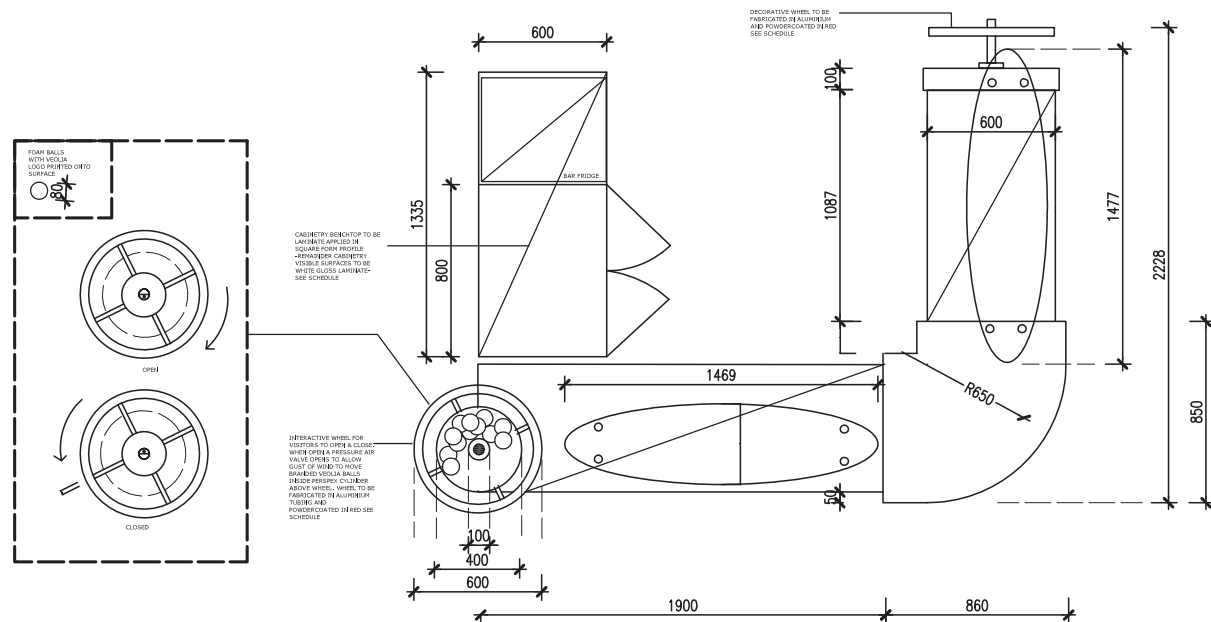

Veolia Water

Interactive Exhibit >> Saudi Water & Power Forum (SWPF) >> Client Approved 2008